



THE WAY
YOU WANT IT

ANY WAY
YOU WANT IT

CREATE YOUR SYMBOL

Configure **your own layout** and create a machine tailored to your exact needs.

MODULAR CONFIGURATION

- 1 or 2 whole bean coffees
- Optional ground coffee
- 1 or 2 soluble ingredients
- Vanilla, Hot Chocolate, Milk or Chai



ACCESSORIES

- Hopper extensions (2-bean model only)
- Base cabinets
- Chute kit for coffee waste
- MDB compatible payment systems
- WIFI connectivity (USB dongle)

SPECIFICATIONS

Weight	Up to 94 lb
Electricity	120 V AC, 15 A, 60 Hz
Water Services	Plumbed or bottled
Water Tank Capacity	0.74 gal
Bean Hopper Capacity*	
1-Bean Model	5.0 lb
2-Bean Model	2.5 lb & 3.0 lb
Ground Coffee Canister Capacity*	0.9 lb
Soluble Canister Capacity*	3.0 lb each
Cup Sizes	3 to 16 oz
Cup Height	Max 5.5 inches
Brew Strengths	3
Branding Options	Video
Screen Customization Capabilities	Yes

*Capacity may vary depending on the product used.

TECHNOLOGY & DESIGN

- 10" HD touch screen
- Burr grinder for each bean hopper
- Compatible with Sophia
- ADA compliant ordering
- Cellular modem (optional for base-line model)
- Sophia Touchless Solutions:
- Contactless ordering through a web-based application

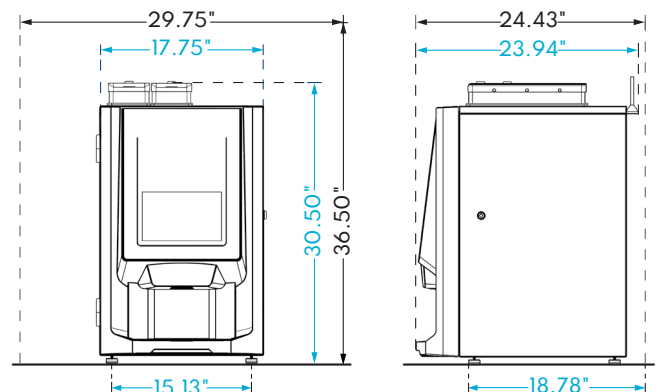

More Info



A brand of
EVOKA
GROUP

